

INTERNATIONAL STANDARD

ISO
9585

First edition
1990-12-15

Implants for surgery — Determination of bending strength and stiffness of bone plates

*Implants chirurgicaux — Détermination de la résistance au pliage et de
la rigidité des plaques pour os*



Reference number
ISO 9585:1990(E)

Foreword

ISO (the International Organization for Standardization) is a worldwide federation of national standards bodies (ISO member bodies). The work of preparing International Standards is normally carried out through ISO technical committees. Each member body interested in a subject for which a technical committee has been established has the right to be represented on that committee. International organizations, governmental and non-governmental, in liaison with ISO, also take part in the work. ISO collaborates closely with the International Electrotechnical Commission (IEC) on all matters of electrotechnical standardization.

Draft International Standards adopted by the technical committees are circulated to the member bodies for voting. Publication as an International Standard requires approval by at least 75 % of the member bodies casting a vote.

International Standard ISO 9585 was prepared by Technical Committee ISO/TC 150, *Implants for surgery*.

© ISO 1990

All rights reserved. No part of this publication may be reproduced or utilized in any form or by any means, electronic or mechanical, including photocopying and microfilm, without permission in writing from the publisher.

International Organization for Standardization
Case Postale 56 • CH-1211 Genève 20 • Switzerland

Printed in Switzerland

Implants for surgery — Determination of bending strength and stiffness of bone plates

1 Scope

This International Standard describes a test method for determining the bending strength and stiffness of straight bone plates. It may also be used to test plates having a small initial curvature intended to produce pre-loading of the bone when fitted and to test the straight portion of angled plates. This test method is not recommended for plates of length less than 50 mm nor for plates designed to be used with, or forming parts of, intramedullary devices.

NOTE 1 A test method for plates of length less than 50 mm is in preparation.

2 Definitions

For the purposes of this International Standard, the following definitions apply.

2.1 moment: Turning effect of a force about an axis, expressed numerically by the product of the force F and the distance h measured perpendicularly from the axis to the line of action of the force.

Unit: N·m

2.2 bending moment, M_b : Moment acting about an axis perpendicular to the long axis of a body and generally producing lateral deflection.

Unit: N·m

2.3 deflection: Linear displacement due to bending measured perpendicular to the original axis of the plate.

Unit: m

2.4 bending strength: Value of the bending moment at fracture, or at a specified proof point, whichever is the lower.

Unit: N·m

2.5 equivalent bending stiffness: Stiffness of the plate calculated from the dimensions of the test configuration and the slope S of the linear part of the load/deflection diagram defined by the mechanical test.

Unit: N·m²

NOTE 2 This equivalent bending stiffness takes account of the holes or slots in the plate.

3 Apparatus

3.1 Test rig, to produce a loading system in accordance with figure 1, the four rollers (indicated by hatched circles) being so constrained that their axes remain parallel.

3.2 Rollers, of cylindrical form and of equal diameters within the range of 8 mm to 13 mm, or of profiled form corresponding to the cross-section of the plate to be tested, and having a mean diameter within the range 8 mm to 13 mm. It is desirable that one of the rollers be secured to the specimen to restrain longitudinal movement and that all rollers are secured to maintain their relative position.

3.3 Means of applying forces, e.g. a mechanical testing machine.

3.4 Device(s), for measurement of relative displacement(s).

4 Procedure

4.1 General

Conduct bending tests using the apparatus specified in clause 3. Use the cylindrical rollers to test flat plates and plates of curved cross-section, in which the deviation from flatness at the centre of the plate does not exceed $b/6$, where b is the width of the plate. Test other plates using rollers of suitable profile.

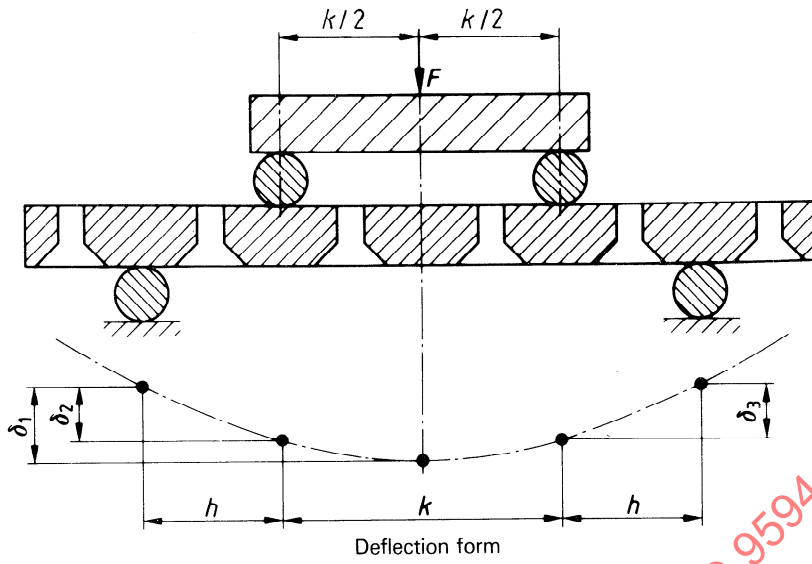

Figure 1 — General arrangement of four-point bend test

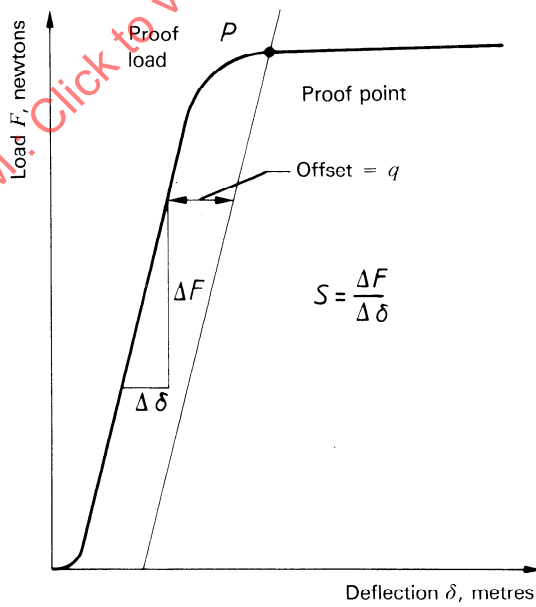

Figure 2 — Load deflection diagram

4.2 Placement of test specimen

Place the test specimen in the test rig and position it in accordance with the following:

- a) Place the plate so that the inner rollers are in contact with the surface of the plate intended to be in contact with bone.
- b) If the plate is symmetrical, place it symmetrically with the two innermost screw holes between the inner rollers.
- c) If the plate has a central screw hole, place it with the central screw hole and one other screw hole symmetrically between the inner rollers.
- d) If the plate is asymmetrical, place it with two screw holes between the inner rollers so that the position of the fracture for which it is intended to be used shall be between the inner rollers.
- e) Position the outer rollers at equal distances of h metres from the inner rollers as shown in figure 1, so that one hole only is in the length between the inner and outer rollers.
- f) Ensure that the inner rollers are not in contact with parts of the plate where there is a screw hole. Wherever possible, the outer rollers should not be in contact with parts of the plate which include a screw hole.
- g) Measure the distance k , in metres, between the inner rollers.
- h) Align the axis of the test specimen to be perpendicular to the axes of the rollers.
- i) Install the device(s) to measure the deflection, in metres, of the plate relative to the initial position of the outer roller supports. The deflection may be measured:
 - 1) on a line midway between the central rollers (δ_1), or
 - 2) at one of the central rollers (δ_2), or
 - 3) at each of the central rollers (δ_2 and δ_3).

If the location of the holes in the plate is not symmetrical relative to its length, method 3) is recommended.

4.3 Applying force F

Apply a force F at the central loading line indicated and measure the corresponding deflections. Gradually increase the value of F noting the corresponding deflections at each interval, and drawing a graph of

F to a base of deflection δ until the value of F is obtained at which either the plate fractures, $F = F_{\max}$, δ or the plate deflects so that the load deflection graph shows appreciable yield ($F = P$) as shown in figure 2.

4.4 Use of specimens

Test each specimen once only and then discard it.

5 Calculation of results

5.1 Mean deflection

If deflections δ_2 and δ_3 are measured as described in 4.2 i) 3), calculate the mean deflection at each stage of the test:

$$\delta_4 = 0,5(\delta_2 + \delta_3)$$

Draw a graph of force F to a base of deflection δ_4 .

5.2 Equivalent bending stiffness

Draw the best straight line through the initial (linear) part of the load deflection diagram as shown in figure 2, where this line has a slope S as shown in figure 2.

If the deflection has been measured as specified in 4.2 i) 1), calculate the equivalent bending stiffness, E , from the expression:

$$E = \frac{(4h^2 + 12hk + k^2)Sh}{24} \quad \dots (1)$$

where

h is the distance between inner and outer rollers, in metres;

k is the distance between inner rollers, in metres;

S is the slope of the load/deflection curve, in newton metres.

If the deflection has been measured as specified in 4.2 i) 2) or 4.2 i) 3), calculate the equivalent bending stiffness, E , by the expression:

$$E = \frac{(2h + 3k)Sh^2}{12} \quad \dots (2)$$

where h , k and S are as above.

5.3 Bending strength

On the graph of load against deflection, draw a straight line parallel to the linear part of the graph, offset by an amount q metres as shown in figure 2. The intersection of this line with the curve is the proof point, and this defines the proof load P .

Calculate q from the expression:

$$q = 0,02(2h + k)$$

Calculate the bending strength, in newton metres, from the expression:

$$\text{Bending strength} = 0,5Ph$$

where

P is the proof load in newtons;

h is the distance between inner and outer rollers, in metres.

If fracture of the plate occurs before the load/deflection curve intersects the offset line, calculate the bending strength, in newton metres, from the expression:

$$\text{Bending strength} = 0,4F_{\max} \times h$$

where

F_{\max} is the maximum load, in newtons;

h is the distance between inner and outer rollers, in metres.

NOTE 3 This expression uses an equivalent proof load, equal to 0,8 times the maximum load.

6 Test report

The test report shall include the following information:

- a) the bending strength, in newton metres;
- b) the offset q , in metres, used to determine the proof point;
- c) the equivalent bending stiffness, in newton metres squared, calculated from equation 1 or 2 as appropriate;
- d) if the plate fractures before the proof deflection is attained, this shall be recorded;
- e) the identity of the plate, e.g. type, length in millimetres, manufacturer's catalogue number and batch number, as supplied by the party requesting the test.

STANDARDSISO.COM : Click to view the full PDF of ISO/IEC 9585:1990/Cor 2:1992